

Planar T* 2/50 ZM

The perspective of the human eye

The new standard for M-bayonet lenses. This lens is based on the renowned Carl Zeiss Planar® design, a symmetric combination of 6 optical elements in 4 groups. Its features include excellent resolving power, high image quality over the entire field, and outstanding flare control. The Planar T* 2/50 ZM lens opens up new creative possibilities for all-round photography, documentation and photojournalism.

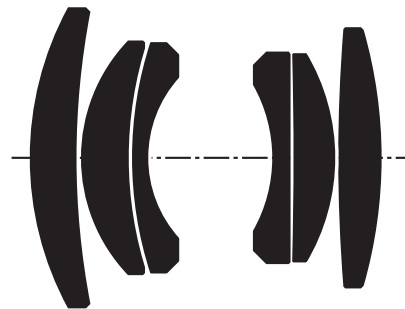
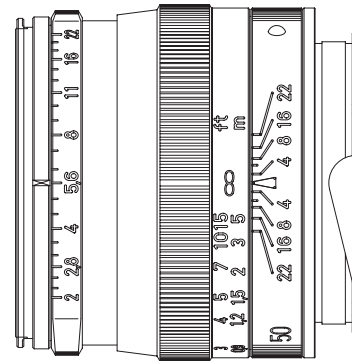

Technical Specifications

Focal length: 50 mm

Aperture range: 2–22

No. of elements/groups: 6/4

Focusing range: 0.7 m–infinity

Image ratio at close range: 1:12

Coverage at close range: 29 cm x 43 cm

Angular field, diag./horiz./vert.: 47/39/27°

Filter: M 43 x 0.75

Weight: 210 g

Length: 51 mm

Cat. No. silver: 30 82055

Cat. No. black: 30 82056

Subject to change.

Carl Zeiss AG

Camera Lens Division
73446 Oberkochen
Germany

Tel: +49 73 64 20-61 75
Fax: +49 73 64 20-40 45
E-Mail: photo@zeiss.de
www.zeiss.de/photo



We make it visible.

Planar T* 2/50 ZM

Performance data

Modulation transfer T as a function of image height and slit orientation: sag _____ tan

White light. Spatial frequencies R = 10, 20 and 40 cycles/mm.

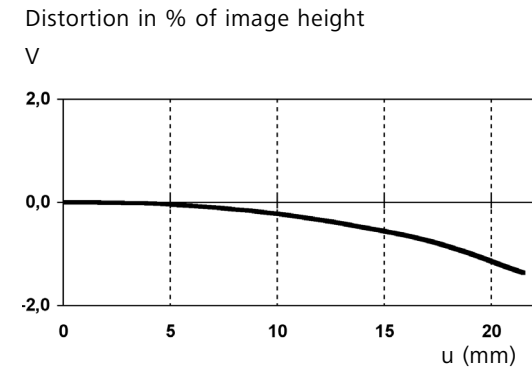

f-number: k = 2.0

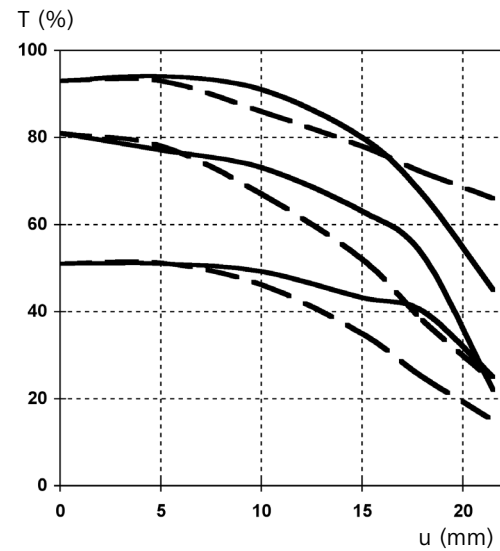

f-number: k = 4.0

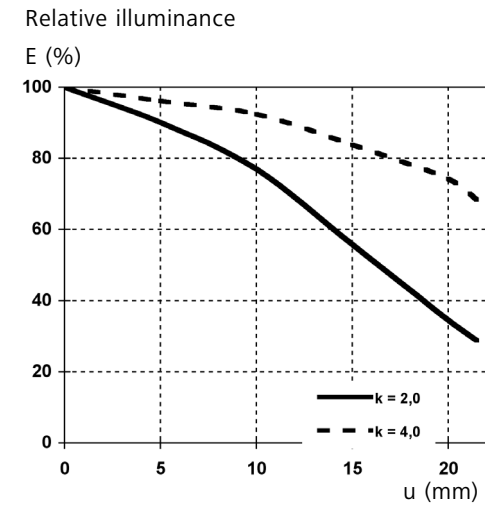
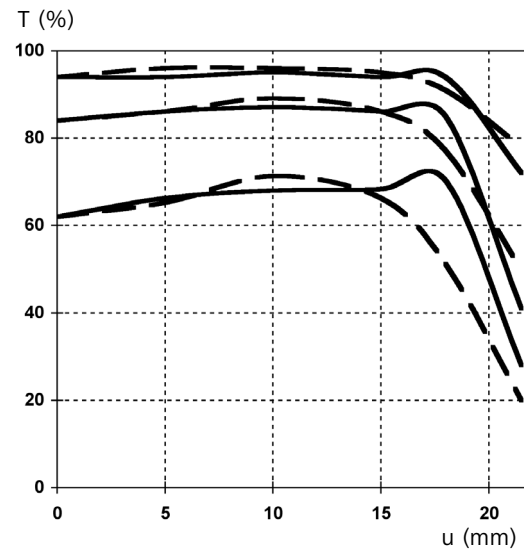

Subject to change.

Carl Zeiss AG

Camera Lens Division
73446 Oberkochen
Germany

Tel: +49 73 64 20-61 75
Fax: +49 73 64 20-40 45
E-Mail: photo@zeiss.de
www.zeiss.de/photo



We make it visible.