

**7** Next, remove the crank from the loader, open the door and take out the cassette. Pull an additional 3-1/2" of the film from the loader for use as a leader when loading the film in the camera. Cut off the film from the bulk roll between the sprocket holes.

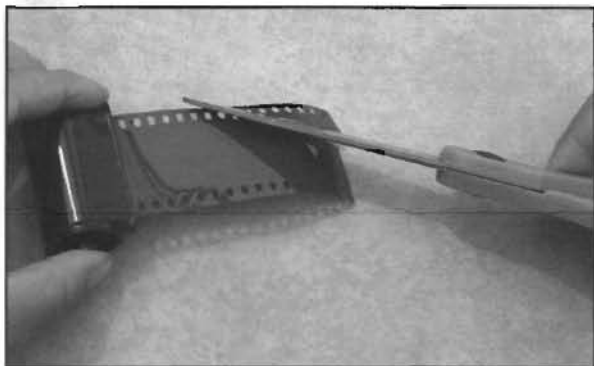

**8** Cut an 1-3/4" to 2" tapered section from the right hand end of the leader (with the leader pointed toward you.)

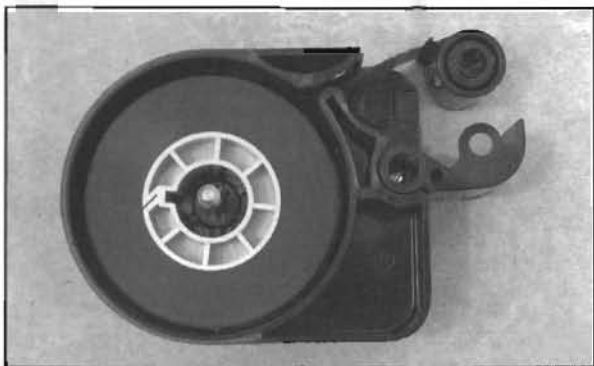

**9** This "cut-away" view shows how cassette, loader and door fit together.

### IMPORTANT!

DO NOT EXPOSE THE LOADER NOR LOAD YOUR CASSETTES IN DIRECT SUN LIGHT.

**THE INITIAL 50 OR 100 FEET FILM ROLL MUST BE LOADED INTO THE LOADER IN A DARK ROOM OR CHANGING BAG, IN COMPLETE DARKNESS.**

Follow these instructions carefully:

1. Unscrew the lock cap and remove the loader cover.
2. Remove the fresh film roll from it's packing and place its hub over the center screw of the loader, make sure that the roll will turn clockwise when unwound.
3. Insert the leading end of the film from the top until it passes freely between the felt light-seal of the loader.
4. Replace the cover and secure with the lock cap (do not over tighten!)

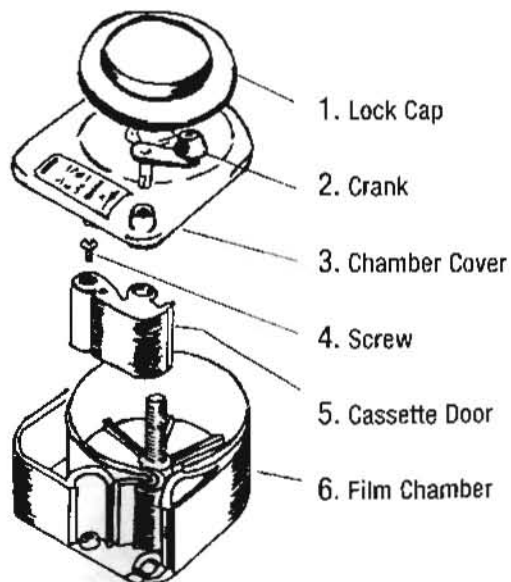

# LegacyPro® LLOYD'S



— The Original —  
**LegacyPro® 35mm  
Lloyd's Daylight  
Bulk Film Loader**

**FS** distribution  
A DIVISION OF FREESTYLE PHOTOGRAPHIC

[www.fsdistribution.biz](http://www.fsdistribution.biz)

# How To Bulk Load 35mm Film...

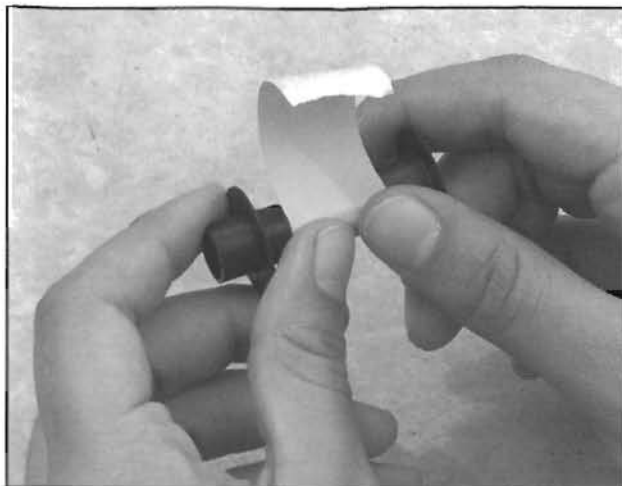

**1** Loading bulk film with the Daylight Bulk Film Loader is shown in these nine steps: Take a 3" length of 1/2" masking or scotch tape. Attach the center of the tape to the spool, allowing the ends to project.

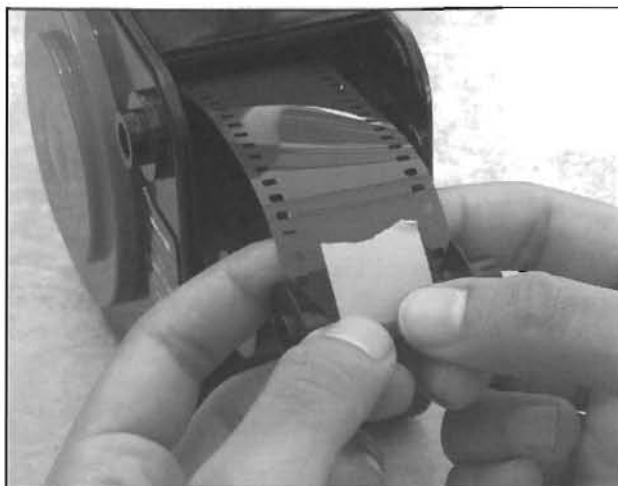

**2** Place end of film against the spool, press one end of tape on top of film and the other end wrap around the spool and tape to the underside of the film. The tape is now looped around the spool and the ends attached to both sides of the film.



**3** Slide cassette case over spool, with film extending through felt light trap.

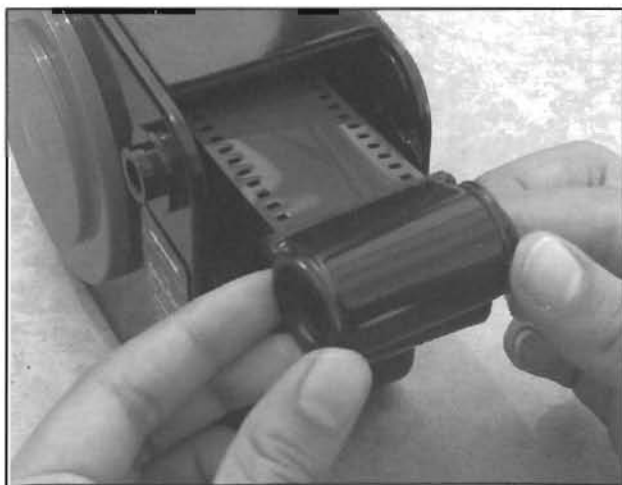

**4** When using reloadable metal cassettes, put an end ring over the spool end and snap over the edges of the spool. Pull down lightly on the end and it will snap into place. Give the ring about 1/8 of a turn to see that it is properly seated into the groove.



**5** With the end ring of the cassette properly fitted against the light trap of the loader, close the door. Insert the crank, which engages the patented automatic lock and prevents film compartment from opening. For the first few rolls loaded, keep loader on its side while winding to prevent scratches on film base.



**6** Hold the loader with the left hand and with your right hand wind the correct number of turns for the exposures you want in the cassette. The turns will vary somewhat with different spool diameters, as some are bigger than others. Generally, 36 exposures in a cassette equals 30 turns of the crank.