

Vivitar



v3800N CAMERA



1. Frame Counter
2. Film Advance Lever
3. Shutter Release Button
4. Shutter Speed Dial
5. Film Speed Dial
6. Lens Load Indication
(In the Surface of Mount).
7. Shutter Speed Index
8. Direct Xcontact
9. Accessory Shoe
10. Focal Plane Indication
11. Film Rewind Crank
12. Film Rewind Knob.
13. Metering Button
14. Multi-Exposure Button
15. Self-timer
16. Lens Release Button
17. Aperture Adjust Ring
18. Focusing Ring
19. Depth of Field Preview Lever
20. Flash Socket
21. Aperture/Distance Index

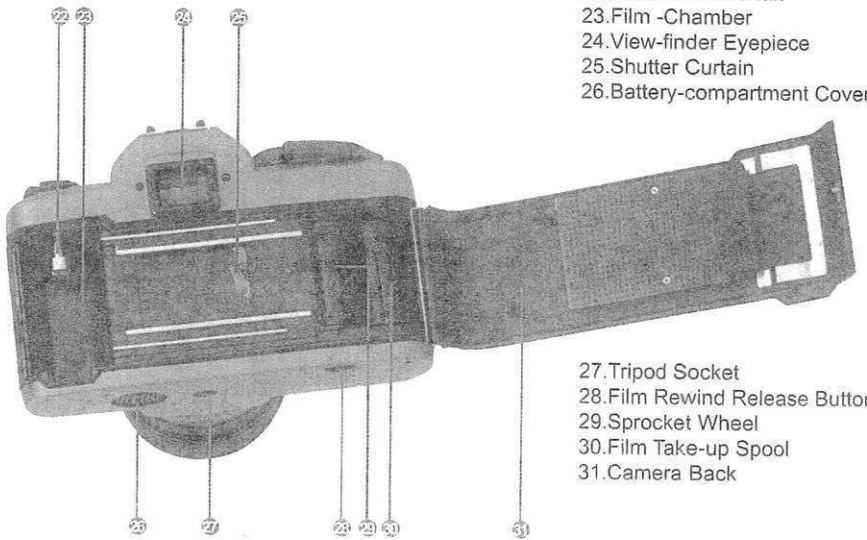

22. Film Rewind Shaft
23. Film -Chamber
24. View-finder Eyepiece
25. Shutter Curtain
26. Battery-compartment Cover
27. Tripod Socket
28. Film Rewind Release Button
29. Sprocket Wheel
30. Film Take-up Spool
31. Camera Back

Before using your camera for the first time, to ensure correct operation and take good care of your camera, please study this book carefully all the way through. As you read, handle your camera to acquaint yourself with its parts and features. In this way you can fully and efficiently use camera with facility.

Mounting and Removing the Lens

Mounting the Lens
First, remove the camera body cap by turning it counter-clockwise. Then align the red dot on the lens barrel with the lens Mounting index on the camera body, fit in the lens and turn it clockwise until it locks in place with a click.

Removing the Lens

- While pressing in the Lens Release Button turn the lens counter-clockwise as far as it will go, then pull it out toward the front. Once the lens has been removed, be sure to put the lens front cap and rear cap on the lens and the body cap on the camera's lens mount to protect them.

- While mounting and removing the lens, do not touch the lens glass or the inside of the camera.

- If you are changing the lens with film in the camera, take care to prevent light from entering the inside of the camera.

Battery Installation

Two 1.5V alkaline batteries(LR44) or 1.55V silver oxide batteries(SR44) are needed to provide power for the camera's exposure meter.

1. Remove the battery Compartment Cover by turning it with a coin.
2. Insert the two batteries inside the battery holder with the plus (+) side facing up. Then replace the holder in the compartment and tighten its cover.

Battery Check

Check the batteries with the LEDs in the viewfinder. If an LED (red or green) turns on when the Shutter Release Button is pressed halfway in, the batteries are in good condition, if no LED turns on, they are exhausted and must be replaced. Be sure to replace the two batteries at the same time. Because the batteries are used to power only the exposure meter, the camera operates even if they are exhausted or there are no batteries in it.

"2" ... "2000" on the dial represent 1, 1/2...1/2000 Sec. and the letter iBf stands for iBulb, used for long exposure as explained below. To set the shutter speed, turn the Shutter Speed Dial and set the number you want opposite in index. Be sure to set it at the click position.

Bulb Exposure Photography

If an exposure time longer than 1 sec is required, set the Shutter Speed Dial at "B" the shutter will remain open as long as the Shutter Release Button is kept depressed. To prevent camera shake, mount the camera on a tripod and trip the shutter with a cable release (optional equipment).

Setting the Aperture

The aperture controls the amount of light that reaches the film. If the Aperture Ring is turned to one-step higher number (from 4 to 5.6, for example), the amount of exposure will be reduced by half; if it is turned to a one-step lower number, the amount of exposure will be doubled. The aperture not only controls the amount of light but also allows you to control the sharpness of areas in front of and behind the subject, as explained later in the section iDepth of Field. To set the aperture, turn the ring and set the number you want

1. Open the camera Back by pulling the Film Rewind Knob all the way out.
2. Install the cassette in the film chamber and push down the Film Rewind Knob, if it does not return smoothly to its original position, push it down while twisting it back and forth.
3. Pull out the film tip and insert it into any one of the slots in the Film Take Up Spool.
4. Operate the Film Advance Lever slowly to advance the film. Make sure the Sprocket teeth catch the perforations and close the Camera Back.
5. Fold out the Film Rewind Crank and turn it gently in the direction of the arrow to take up the film slack.
6. Wind the Film Advance Lever and depress the Shutter Release Button. Repeat this operation until the Exposure Counter shows 11. The film is advancing properly, the Film Rewind Knob turns while you wind the Film Advance Lever.

Film Advance Lever

By turning the Film Advance Lever as far as it will go,

(with click) opposite the aperture/Distance index. Intermediate setting can also be used.

Exposure Setting

Your camera features a center-weighted metering system which measures the light intensity with emphasis on the subject in the center of the viewfinder. It also measures the brightness in the surrounding area.

The camera operates on manual exposure. First, set the film speed, you can then use appropriate combination of shutter speed and aperture to obtain correct exposure. If you press the Shutter Release Button halfway in, the exposure meter will switch on and an LED will turn on in the viewfinder to indicate exposure. The LED will turn off as soon as you take your finger off the button.

As the exposure meter is based on a center-weighted system, always place your subject in the center of the viewfinder for light metering.

Correct Exposure

Only the green circle LED turns on. If the green LED and a red+ or - LED turn on at the same time, it

the film will advance one frame and the shutter will be cocked at the same time, unless it is fully turned, the shutter cannot be released.

Exposure Counter

The Exposure Counter will advance each time the Film Advance Lever is wound and will return to "S" when the Camera Back is opened. It displays the letter "S" and numbers 1, 4, 6... up to 36. The numbers 12, 20, 24 and 36 are marked in orange to indicate the end of film in commercially available film cassettes.

Setting the Film Speed

To obtain correct exposure, it is important to set the film speed correctly. The speed of the film you are using is printed on the film box.

To set the film speed, lift up the film Speed Ring and turn it until the desired ISO speed comes opposite the index mark (▼).

The ISO speed setting on the Film Speed Ring are as follows

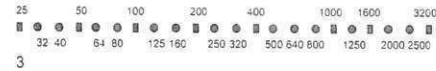

3

means slight over or underexposure. But you can go ahead and shoot. However, if you are using a shutter speed of 1/30 sec. or slower. Mount the camera on a tripod to prevent camera shake or use flash photography instead.

Overexposure

Only the red n LED turns on. It means your subject is too bright stop down the aperture (i.e. set a higher number) or use a faster shutter speed to turn on the green LED

Underexposure

Only the red-LED turns on it means your subject is too dark. Open up the aperture (set lower number) or use a slower shutter speed to turn on the green LED.

Taking Pictures

1. Set the shutter speed and aperture. Turn the shutter speed dial and aperture ring to set your desired values. Focus the lens and frame your subject.
2. While looking through the viewfinder. Turn the focusing ring to focus and compose your picture.

Focusing the Lens

Focusing is done with a split-image focusing center microprism collar and a surrounding matte screen.

Focusing with the Split-Image

Turn the Focusing Ring until the two segments of the image divided by horizontal line in the split-image center fall in line. If the two segments are not aligned, your subject is not in sharp focus.

Focusing with the Microprism Collar and Matte Screen

Turn the Focusing Ring until your subject in the microprism collar or the matte screen appears sharp. It is not in sharp focus if the image appears wavy on the microprism or blurred on the matte screen.

Shutter Speed and Aperture

Setting the Shutter Speed

The shutter controls the time during which light reaches the film. If the Shutter Speed Dial is turned to a one-step higher number (from 125 to 250, for example), the amount of exposure will be reduced by half; if it is turned to a one-step lower number, the amount of exposure will be doubled. The numbers "1",

3. check the exposure and shoot Press the shutter release button halfway in and check if the green LED turns on in the viewfinder if it turns on, take your picture by pressing the shutter release button all the way in.

Film Rewinding

If you reach the end of the film, the film advance lever will no longer operate. Do not force it. Check the Exposure Counter it make sure the end of the film is reached, rewind the film back into its cassette and unload the cases, send the exposed film for processing as soon as possible. To rewind the film.

1. Press in the rewind release button located on the camera bottom. You need no keep pressing it
2. Fold out the film rewind crank and turn it in the direction of the arrow. Stop winding after you feel a sudden release of tension. Then open the camera back and take out the cassette.

Exposure Compensation

If there is a significant difference in brightness between the main subject and its background, you will

not be able to get correct exposure in the normal metering procedure. In this case, exposure compensation is necessary.

Taking Backlighted Subjects

If you are taking a backlighted subject or if a bright background occupies a large area of the picture frame (e.g. portraits with a bright sky or sea in the background subjects standing against a window etc), your subject will turn out underexposed and dark in such cases, give twice or four times as much exposure so that it is correctly exposed

Example

If the camera's exposure meter indicated F/16 and 1/250 sec. to get correct exposure, make compensation as follows:

Compensation with the aperture ring

For 2x exposure compensation, turn the ring from f/16 to f/11, and for 4x compensation turn it to f/8.

Compensation with the shutter Speed Dial

For 2x exposure compensation turn the dial from 1/250 sec. to 1/125 sec. and for 4x compensation to 1/60

Taking Spotlited Subjects

If a dark background occupies a large area of the picture frame (e.g. spotlited subjects on a stage). Your subject will turn out overexposed and light. In such cases reduce the amount of exposure to half of one fourth so that it is correctly exposed.

Example:

If the camera's exposure meter indicated f/4 and 1/60 sec. To get correct exposure, make compensation as follows:

Compensation with the Aperture Ring

For 1/2x exposure compensation, turn the ring from f/4 to f/5.6 and for 1/4x compensation turn it to f/8.

Compensation with the shutter Speed Dial

For 1/2x exposure compensation, turn the dial from 1/60 sec. to 1/125 sec. and for 1/4x compensation to 1/250.

Using the Self-Timer

If you want to include yourself in the picture, mount the camera on a tripod and trip the shutter with the aid of the self-timer.

1. First, focus the lens and set the exposure.

set. Depth of Field Preview function was designed to avoid this inadequacy.

How to Use

After lens is focused on subject and completed focus, to put the depth of field preview lever, the lens aperture is being contracted and actual depth of field appear. At this time, seeing through focus screen the blurry image behind and in front of subject becomes clear. The clear extension behind and in front of subject is actual size of depth of field. If the depth of field is too narrow or extent, the reset the aperture ring. Repeating the operation, you can get the depth of field you desire.

After getting much experience, you can get more accurate operation on depth of field preview.

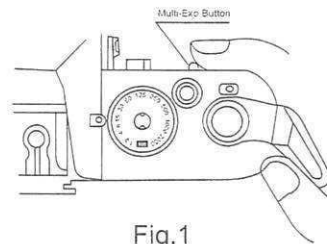

Fig.1

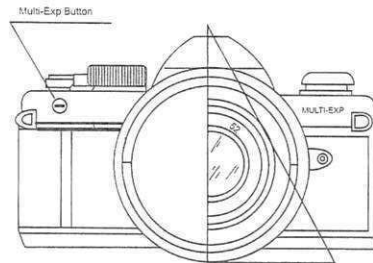

Fig.2

2. Set the self-timer by pushing the self timer lever all the way down. (The self-timer be set after advancing the film.)
3. Make sure the film has been wound and depress the shutter release button. The self-timer will start and trip the shutter in about 10 seconds.

Flash Photography

If you are taking indoor or nighttime pictures, use a compact flash. It will give you beautiful flash pictures. The camera has an X-contact hotshoe which allows flash synchronization at shutter speeds of 1/25 sec. or slower. You can use any type of cordless electronic flash. If you want to use a flash with a PC cord, this camera also has a PC connector on the front of the camera body to the right of the lens.

Depth of Field

When the lens is focused on a subject, that will turn out sharpest in the picture. However, the zone of sharpness extends over a certain distance in front of and behind the point the lens is focused on. This is known as the depth of field of a lens and it varies as follows:

1. The smaller the aperture, the greater the depth of

field, and vice versa.

2. The longer the camera-to-subject distance, the greater the depth of field, and vice versa. The zone of sharpness behind the point the lens is focused on is greater than that in front of it.
3. A lens with a shorter focal length has a greater depth of field than one with a longer focal length.

Depth of Field Scale

You can check the zone of sharpness on the Depth of Field Scale of your lens. If you are using a 50mm normal lens and have set the distance at 5m and aperture at f/16, you will see on the Depth of Field Scale that the zone of sharpness extends from about 2.7m to infinity.

Depth of Field Preview

Usually, when camera is being focused, the lens aperture is in the most open in order to view subject better and focus accurate, but it is cannot be seen directly the actual depth of field when aperture ring is being

Multi-exposure

Though this function, you can take two or more shootings on the same frame, so as to get an artistic image. When you use this function, after taking the first part-shooting, while pulling the "Multi-Exp. Button" down, you can advance the winding crank to charge the shutter without any moving on the film and the film counter, then take the second part shooting. Repeating this operation can take multi-exposure shooting on the same frame.

Using the Frame Divider

The Frame Divider composed of the Lens Hood and the Picture Divider. First, screw the Lens Hood (M52) on the lens, then put the picture Divider on the lens Hood, ensure the line connecting the two index dots on the picture divider vertical to the camera bottom surface: (figure 2): 1/2 frame, 3/4 frame, 1/4 frame, (combination of 1/2 and 3/4 frame) is available for the picture Divider, selected by the user. When shooting by Multi-exposure, camera must be fixed on tripod. Care operation is necessary to avoid any displacement of each divided picture.

9

Overlapping area in film-divided picture and use of aperture value.

Exposure for 1/2 picture in the film is accessible when using 1/2 picture Divider. Use split-image center to compose the picture when you look through the viewfinder. If take film-dividing picture to the left and right theoretically picture-dividing line is through the center of focusing screen, which means that the image you watch from the viewfinder on the right can be exposed in the picture while covering the left side and vice versa. The fact that boundary has a certain overlapping area because the surrounding and radiation of the light requires the Subject not to close to the center boundary, when picture-dividing to the left and right, an overlapping area exists, whose width is equal to or less than the diameter of micro-prism circle (figure 3)

The subject that will be photographed for two times can not enter this area, otherwise, the image of the subject and background will interfere.

The overlapping area changes as the aperture

changes. The bigger the aperture diameter, the wider the overlapping area becomes, and vice versa. The central part will have over-exposure, if the overlapping area is too wide, and it will have under-exposure if too narrow. The suitable value is $F8 \pm 1/2$.

Metering Compensation when using Film Divider.

The metering will be affected by the Film Divider, so that the metering result can't show the needed exposure. Compensation is necessary in this case to get correct exposure.

1. When dividing picture to the left and right reduce the amount of exposure to the half.
Example: If the camera's exposure meter indicates $F8, 1/30$ sec., to correct exposure, turn it to $F8, 1/60$ sec., or turn to $F11, 1/30$ sec.
2. When dividing picture to up and down, no compensation needed to exposure on downside, but in case of exposure on upside, reduce the amount of exposure to one-fourth.
Example: If the camera's exposure meter indicates $F8, 1/30$ sec., no change for exposure downside, but for exposure upside, turn it to $F8, 1/125$ sec.

How to focus when half of split-image darken.

The phenomena will appear when using Film Divider or zoom lens. In this case, you can focus through the microprism / Fresnel hoop.

When your eye move to left or right and watch the image in the viewfinder, you can also use the split image to focus.

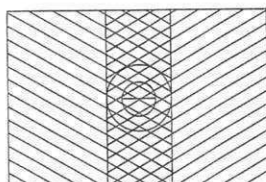

(Fig. 3)

Overlapping area

10

Viewfinder: eye-level pentaprism finder; 92% field of view and 0.91X magnification (with 50mm lens at infinity)

Focusing screen: split-image / microprism

Viewfinder information: display of correct exposure, over and under exposure with 3 LEDs

Film advance: lever with 130° stroke and 20° stand-off.

Film rewind: film rewind crank

Exposure counter: additive, auto reset

Dimensions: 135 (W) X 584.5 (H) X 50 (D) mm

Weight: 445g (without batteries).

Specifications and design subject to change without notice.

12

Camera Care

- Do not leave the camera in a hot place (e.g. in direct sunlight, in a closed car, etc.) for too long a time, because excessive heat may adversely affect the film, batteries or camera mechanism. If the camera has become too hot, allow it to cool to normal temperature before use.
- After shooting seaside scenes, clean the camera very carefully, sea breezes may cause corrosion of the camera mechanism.
- Remove the dust and dirt on the lens and viewfinder eyepiece with a soft lens brush or blower brush. Remove fingermarks by wiping off lightly with lens tissue. In case the mirror is soiled dust off lightly with a lens brush. Always take extra care to avoid scratches.
- Do not subject the camera to abrupt temperature changes, because moisture can condense inside the camera and cause fault electrical contact.
- To clean the camera body, wipe it clean with a soft cloth. Never use benzine, thinner or other solvents.
- If you are not likely to use the camera for an extended period of time, remove the batteries and

11

store it away from heat and moisture

- Before you take your camera on a trip or for a special event, be sure to check beforehand that it functions normally.
- Keep in mind that the picture area that will appear on a certain size of print may be slightly smaller than that of the negative.

Battery Precautions

- Silver-oxide batteries will last about one year and alkaline batteries about six months. However, their service life differs depending on their capacity at the time of purchase the ambient temperature and how often you take pictures.
- Generally, the battery performance decreases temporarily at low temperatures (under about 0°C/32°F). when taking pictures in cold weather, it is recommended to use new batteries and warm the camera before shooting. The batteries affected by cold temperatures will function properly again if they return to normal temperature.
- Before installing the batteries, wipe both poles clean with a dry cloth, because poor contact may result if they are soiled.
- If you are carrying your camera on a long trip, bring

spare batteries with you.

- Never put batteries into fire to try to disassemble them because it is dangerous.

Specifications

Type: 35mm single lens reflex camera with focal plane shutter.

Negative size: 24 x 36 mm

Lens mount: PK mount

Shutter: vertically running metal focal plane shutter.

Shutter speeds: B (bulb), 1 to 1/2000 sec. (13 steps)

Flash synchronization: X contact hotshoe (Synchronizes at 1/125 sec. or slower) Connector for PC cord.

Self-timer: mechanical with about 10 sec. delay.

Shutter release: mechanical

Exposure metering: Through-the-lens, full-aperture, center-weighted light metering with SPD cell;

Manual exposure with LED display: metering range EV2-19 (with ISO 100 film and 50 mm f/1.4 lens);

ISO 25-3200 film speed range; exposure meter switch activated by pressing shutter release button halfway in.

Exposure meter power source: two 1.5V alkaline (LR44) or 1.55V silver-oxide (SR44) batteries.